

刀塔干涉圖

Turret Intervene Stroke

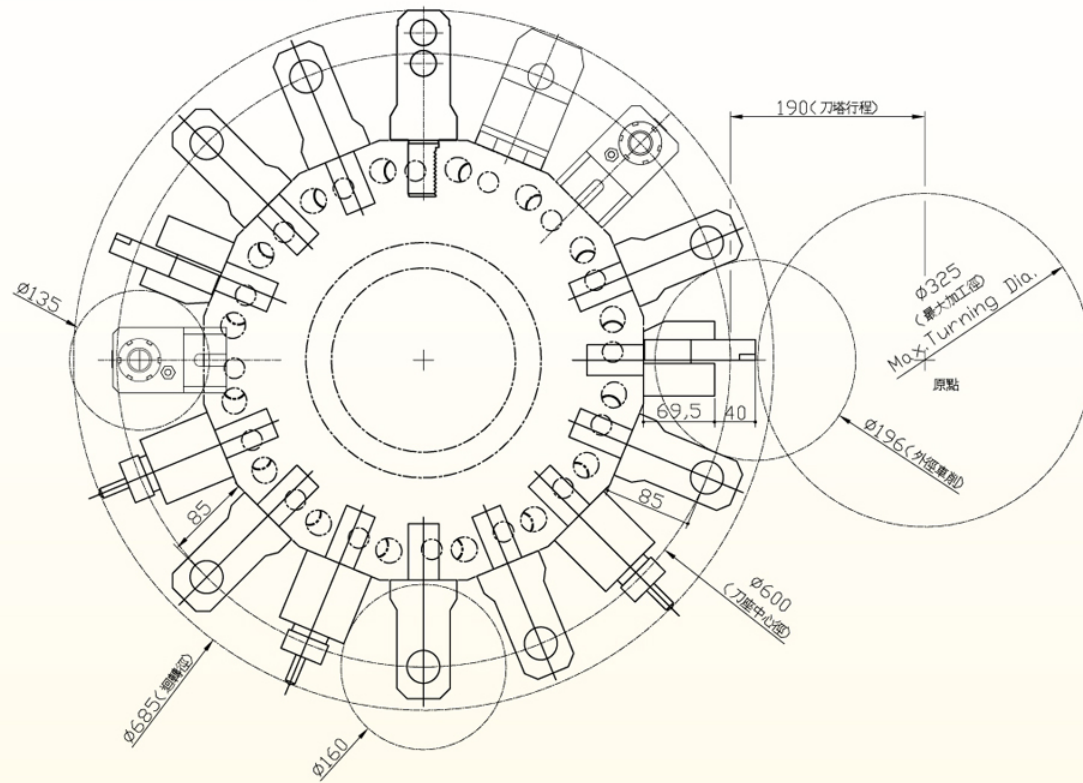

佔地面積圖

Dimensions Of Machine

- 長×寬×高(L×W×H) : 4425×2713×2221
- 重量 (Weight) : 10000 kg

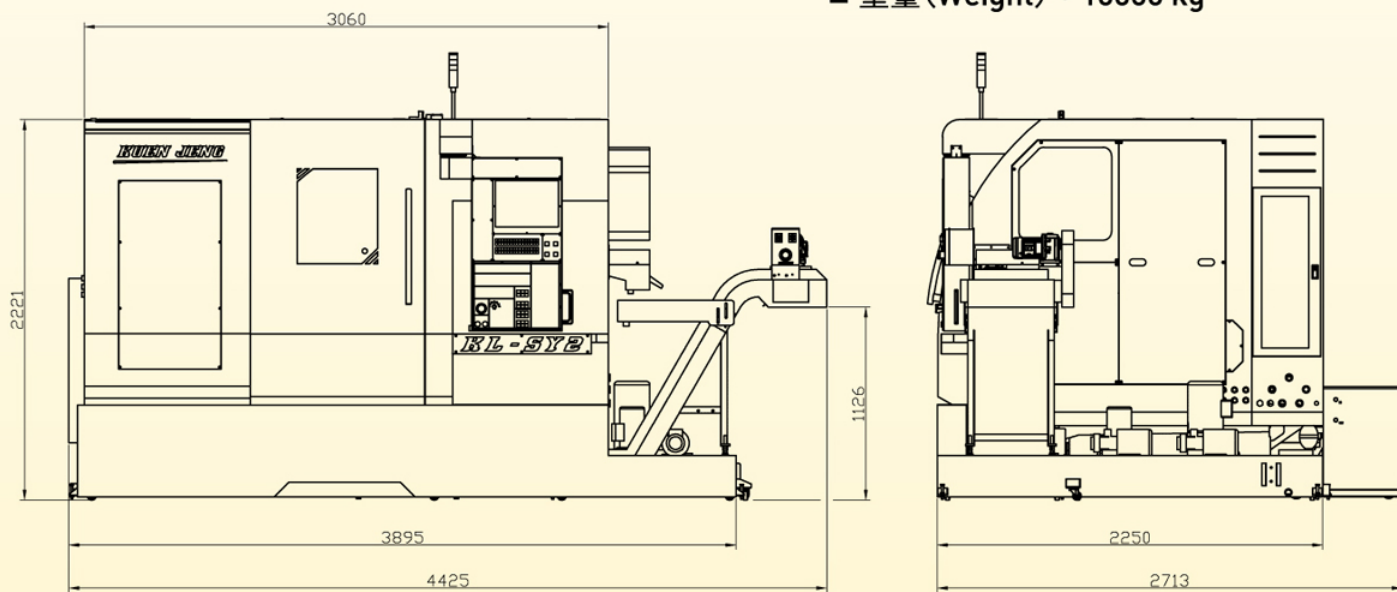

※尺寸規格若有變動恕不另行通知

經銷商 Agent



坤鈺機械股份有限公司
KUEN JENG MACHINERY CO., LTD.

42742台中市潭子區豐興路2段338巷10-2號
 No.10-2, Ln. 338, Sec. 2, Fengxing Rd., Tanzi Dist., Taichung City 42742, Taiwan
 TEL: 886-4-25369498 E-mail: sales@kuen-jeng.com.tw
 FAX: 886-4-25367405 www.kuen-jeng.com.tw



KL-SY2

雙主軸 /
 雙刀塔CNC車床

Twin Spindle /
 Twin Turret CNC Lathe

High Accuracy, Versatile,
 An Extra Value Series!

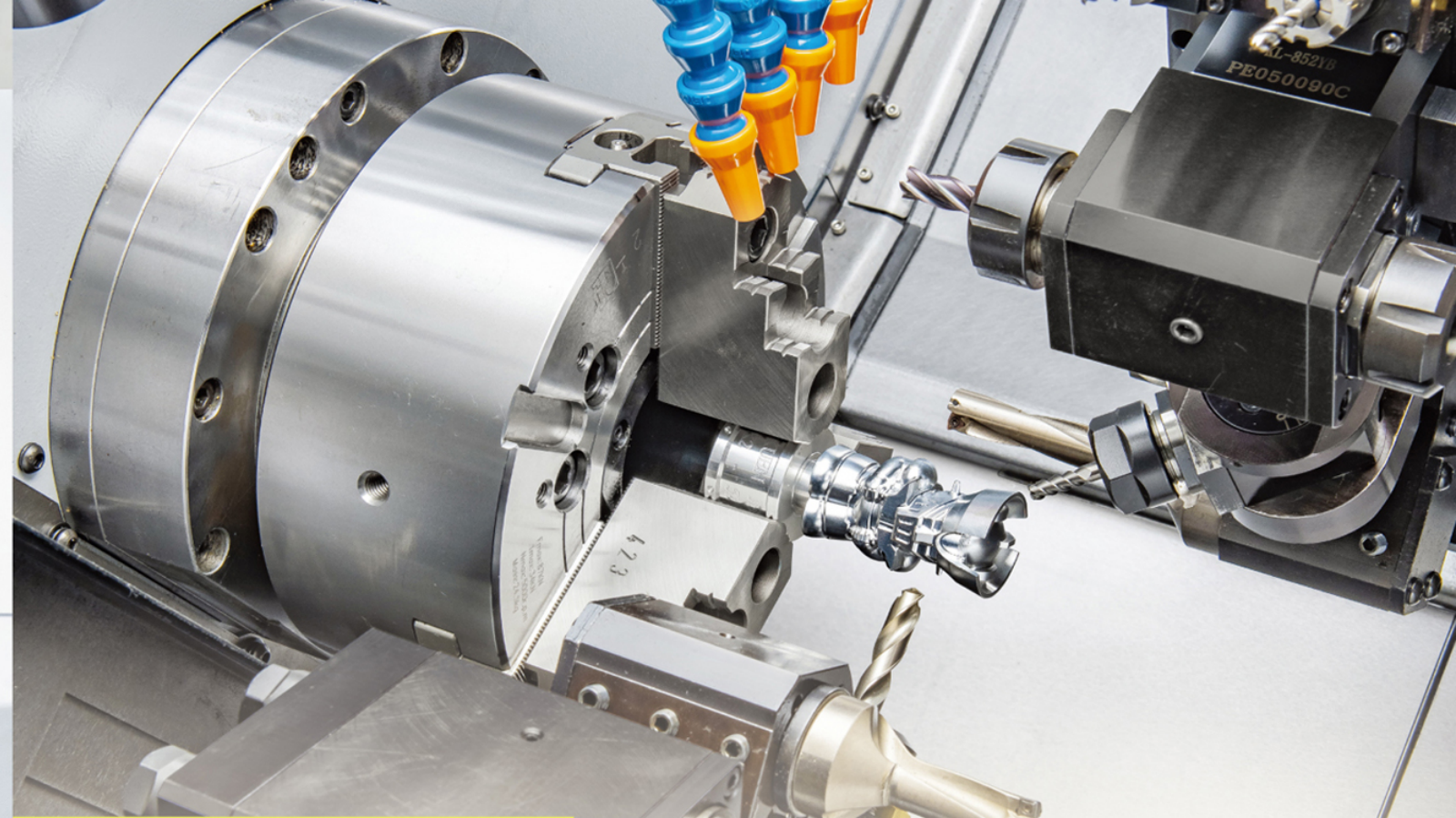
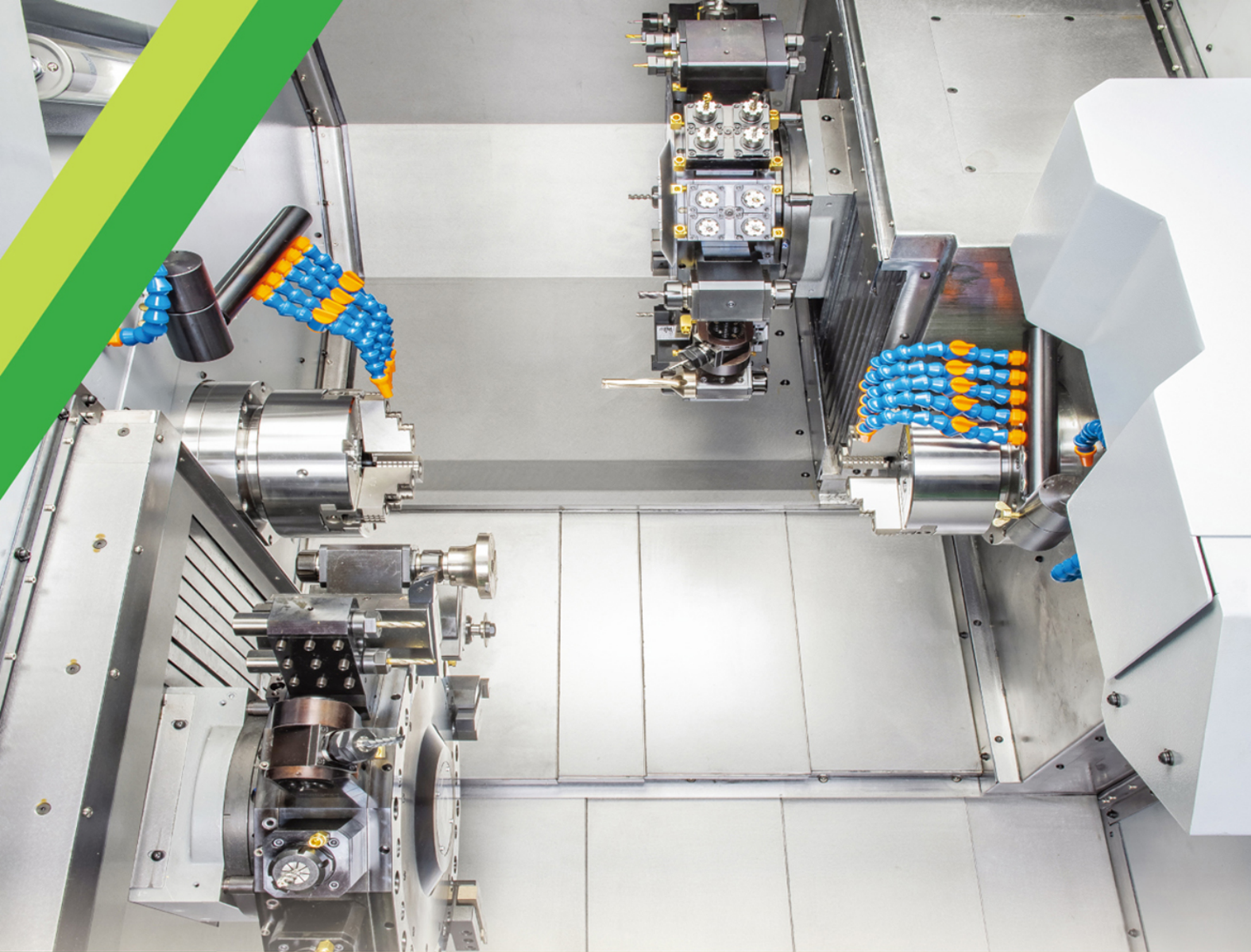

加工行程圖

Machining Stroke Diagram



KL-SY2 雙主軸 / 雙刀塔CNC車床

Twin Spindle / Twin Turret CNC Lathe

- 主軸馬達功率 α 15 / 15 kw
- 主軸最高轉速 3500 rpm
- 副主軸馬達功率 α 6 / 5.5 kw
- 副主軸最高轉速 3500 rpm
- 最大加工直徑 $\left\{ \begin{array}{l} \text{X1軸 } \phi 210 \text{ mm} \\ \text{X2軸 } \phi 210 \text{ mm} \end{array} \right.$
- 最大加工長度 600 mm
- 最大拉桿通孔直徑 52 mm
- 45° 斜床式結構
- 16位Duplomatic VDI 30動力刀塔
- X1、Z1、Y1、X2、Z2、Y2、B軸
配置精密線型滑軌
- FANUC 31i CNC控制器
- Spindle motor α 15 / 15 kw
- Max. spindle speed 3500 rpm
- Sub-spindle motor α 6 / 5.5 kw
- Max. sub-spindle speed 3500 rpm
- Max.turning diameter $\left\{ \begin{array}{l} \text{X1-axis } 210 \text{ mm} \\ \text{X2-axis } 210 \text{ mm} \end{array} \right.$
- Max.turning length 600 mm
- Max.hole through spindle diameter 52 mm
- 45° slant bed construction
- 16-position duplomatic VDI 30 power turret
- Precision linear guideway on X1、Z1、Y1、
X2、Z2、Y2、B-axis
- FANUC 31i CNC controller